

MACX MCR-EX-SL-NAM-R(-SP)



Intrinsically safe NAMUR isolating amplifier with relay output

INTERFACE

Data sheet
103463_en_00

© PHOENIX CONTACT - 08/2008

1 Description

The NAMUR **MACX MCR-EX-SL-NAM-R(-SP)** isolating amplifier has been designed for intrinsically safe operation of the proximity sensors (as per EN 60947-5-6 (NAMUR)) and the floating and resistance circuit mechanical contacts installed in the Ex area.

The input circuit is monitored for line faults (breakage and short circuit (LFD)) (can be switched on/off). Errors are indicated via a red flashing LED (as per NE 44) and the relevant output relay is de-energized. Error messages are also transmitted to the power and error evaluation module via the DIN rail connector.

A relay (PDT) is provided as a signal output. The switch can be used to set the direction (open or closed circuit current behavior). Readiness for operation is signaled via a green LED. The relay status is indicated via a yellow LED.

The modules can be installed in zone 2 with the "n" (EN 60079-15) protection type.

1.1 Properties

- Input for NAMUR proximity sensor or switch, [Ex ia] IIC
- Relay signal output (N/O contact)
- Line fault detection (LFD)
- Option of phase reversal
- 3-way electrical isolation
- SIL 2 according to EN 61508
- Installation in Zone 2 permissible
- Power supply and error message possible via the DIN rail connector
- With screw (MACX MCR-EX-SL-NAM-R) or spring-cage connection (MACX MCR-EX-SL-NAM-R-SP)



WARNING: Explosion hazard

The module is an associated item of electrical equipment for intrinsically safe circuits. It is designed for use in zone 2, if specific conditions are observed.

When installing and operating the device, the applicable safety directives (including national safety directives), accident prevention regulations, as well as general technical regulations, must be observed.



WARNING: Explosion hazard

Be sure to observe the safety regulations and installation notes on page 5.



Make sure you always use the latest documentation. It can be downloaded at www.download.phoenixcontact.com.

A conversion table is available on the Internet at www.download.phoenixcontact.com/general/7000_en_00.pdf.



This data sheet is valid for all products listed on the following page:

Table of contents

1	Description.....	1
2	Ordering data.....	2
3	Technical data	2
4	Safety regulations and installation notes.....	5
5	Installation	6
6	Configuration	8
7	Comparison of safety data	10
8	Switch on	10
9	Safety-related applications (SIL 2).....	11

2 Ordering data

NAMUR isolating amplifiers

Description	Type	Order No.	Pcs./Pkt.
Intrinsically safe NAMUR isolating amplifier, with relay output and screw connection	MACX MCR-EX-SL-NAM-R	2865434	1
Intrinsically safe NAMUR isolating amplifier, with relay output and spring-cage connection	MACX MCR-EX-SL-NAM-R-SP	2924045	1

Accessories

Description	Type	Order No.	Pcs./Pkt.
DIN rail connector (T-BUS), 5-pos., for bridging the supply voltage, can be snapped onto NS 35/... DIN rails according to EN 60715	ME 6.2 TBUS-2 1.5/5-ST-3.81 GN	2869728	10
Power and error evaluation module, including the relevant DIN rail connector ME 17.5 TBUS 1.5/5-ST-3.81 GN			
Screw connection	MACX MCR-PTB	2865625	1
Spring-cage connection	MACX MCR-PTB-SP	2924184	1



For additional accessories, please refer to the "INTERFACE" catalog from Phoenix Contact.

3 Technical data

Input	
Input	Intrinsically safe, designed for protection type Ex-i [Ex ia] IIC
Available input sources	<ul style="list-style-type: none"> NAMUR proximity switches according to EN 60947-5-6 or Switch contacts with open circuit (not for safety-related applications, SIL 2) or Switch contacts with resistance circuit
Switching hysteresis	< 0.2 mA

Control circuit

Non-load voltage	8 V DC \pm 10%
Switching points according to EN 60947-5-6	I < 1.2 mA (blocking) I > 2.1 mA (conductive)
Line fault detection	Break 0.05 mA < I _N < 0.35 mA Short circuit 100 Ω < R _{sensor} < 360 Ω Activated /deactivated via DIP switch

Switching output

Switching output	Relay, 1 PDT
Switching behavior	Can be inverted using DIP switch
Switching frequency	20 Hz (without load)
Maximum switching voltage	250 V AC (2 A) 120 V DC (0.2 A) 30 V (2 A)
Maximum switching power	500 VA
Contact material	AgSnO ₂ , gold-plated
Service life	
Mechanical	10 ⁷ cycles
Recommended minimum load	5 V/10 mA

General data

Supply voltage range	19.2 V DC ... 30 V DC
Current consumption, maximum	21 mA (24 V DC)
Power dissipation	< 650 mW
Electrical isolation	
Input/output	375 V (peak value according to EN 60079-11)
Input/power supply	375 V (peak value according to EN 60079-11)
Input/power supply, DIN rail connector	300 V _{rms} (rated insulation voltage, surge voltage category II, pollution degree 2, safe isolation as per EN 61010, EN 50178) 1.5 kV AC (50 Hz, 1 min., test voltage)
Output/input, power supply, DIN rail connector	300 V _{rms} (rated insulation voltage, surge voltage category III; pollution degree 2, safe isolation as per EN 61010, EN 50178) 2.5 kV AC (50 Hz, 1 min., test voltage)
Ambient temperature	
Operation	-20°C ... +60°C (any mounting position)
Storage/transport	-40°C ... +80°C
Permissible humidity (operation)	10% ... 95% (no condensation)
Status indicator	Green LED (PWR, supply voltage) Red LED (LE, line errors) Yellow LED (OUT, switching state)
Housing material	PBT
Color	Green
Degree of protection	IP20
Width x length x height	12.5 mm x 114.5 mm x 104 mm (with connection terminal block)
Inflammability class according to UL 94	V0
Design	Terminal block housing for mounting on DIN rails

Conformance

EMC directive 2004/108/EC	EN 61000-6-2, EN 61000-6-4, EN 61326-1
Ex directive (ATEX)	EN 60079-0, EN 60079-11, EN 60079-15

Safety data according to ATEX for intrinsically safe circuits

Maximum voltage U_o	9.6 V							
Maximum current I_o	10 mA							
Maximum power P_o	25 mW							
Maximum inner inductance L_i	Negligible							
Maximum inner capacitance C_i	11 nF							
Gas group	IIC				IIB			
Maximum external inductance L_o	100 mH	5 mH	1 mH	10 μ H	100 mH	5 mH	1 mH	10 μ H
Maximum external capacitance C_o	510 nF	840 nF	1.2 μ F	3.6 μ F	2.7 μ F	4.4 μ F	6.3 μ F	26 μ F
Safety-related maximum voltage U_m	253 V AC (125 V DC)							

Certificates

ATEX	Ex II (1) GD [Ex ia] IIC, IIB IBExU 07 ATEX 1069 Ex II (3) G Ex nAC II T4 X
IECEX approval	[Ex ia] IIC; [Ex ia D]; Ex nAC IIC T4 IECEX IBE 08.0001X
UL USA/Canada	Applied for
Functional safety (SIL)	SIL 2 according to EN 61508

Connection data MACX MCR-EX-SL-NAM-R

Conductor cross-section	
Solid (minimum/maximum)	0.2 mm ² /2.5 mm ²
Stranded (minimum/maximum)	0.2 mm ² /2.5 mm ²
AWG/kcmil (minimum/maximum)	24/14
Stripping length	7 mm
Connection method	Pluggable screw connection
Tightening torque	0.5 Nm, minimum/0.6 Nm, maximum

Connection data MACX MCR-EX-SL-NAM-R-SP

Conductor cross-section	
Solid (minimum/maximum)	0.2 mm ² /1.5 mm ²
Stranded (minimum/maximum)	0.2 mm ² /1.5 mm ²
AWG/kcmil (minimum/maximum)	24/16
Stripping length	8 mm
Connection method	Spring-cage connection

4 Safety regulations and installation notes

4.1 Installation and operation

Follow the installation instructions.



NOTE: Installation, operation, and maintenance may only be carried out by qualified specialist personnel.

When installing and operating the device, the applicable safety directives (including national safety directives), accident prevention regulations, as well as general technical regulations must be observed.



NOTE: The circuits inside the device must not be accessed.

Do not repair the device yourself, but replace it with an equivalent device. Repairs may only be carried out by the manufacturer.



NOTE: The device is designed to meet IP20 protection when:

- It is installed outside potentially explosive areas.
- The environment is clean and dry.

Install the device in a suitable housing with a suitable degree of protection in accordance with IEC 60529 in order to protect it from mechanical and electrical damage.

For the safety data, please refer to the operating instructions and certificates (EC type-examination, other approvals, if necessary).



NOTE: The load connected to the relay outputs should be limited to the values listed in the technical data.

4.2 Safety regulations for installation in potentially explosive areas

Regulations for intrinsically safe circuits



WARNING: Explosion hazard
When carrying out **measurements** on the intrinsically safe side, be sure to observe the relevant regulations regarding the connection of intrinsically safe equipment.
Only use devices approved for use in intrinsically safe circuits.



WARNING: Explosion hazard

If the device has been used in **non-intrinsically safe circuits**, it must **not** be used again in intrinsically safe circuits. Clearly label the module as being non-intrinsically safe.

Installation in Zone 2



WARNING: Explosion hazard

The device is associated equipment of the "Ex-i" protection type and suitable for installation in Zone 2.

Observe the specified conditions for use in potentially explosive areas.



WARNING: Explosion hazard

Install the device in suitable **housing with a minimum of IP54 degree of protection**. Observe the requirements of IEC 60079-14/EN 60079-14, e.g., steel housing with a wall thickness of 3 mm.



WARNING: Explosion hazard

Disconnect the block **power supply before**:

- Snapping it on or disconnecting it.
- Connecting or disconnecting cables of non-intrinsically safe circuits.



WARNING: Explosion hazard

Only use category 3G modules (ATEX 94/9/EC).

Installation in areas with a danger of dust explosions



WARNING: Explosion hazard

The device is **not** designed for installation in areas with a danger of dust explosions.

Connection to the **intrinsically safe circuit in areas with a danger of dust explosions** (zones 20, 21, and 22) is **only** permitted if the equipment connected to this circuit is approved for this zone (e.g., category 1D, 2D or 3D).

4.3 Use in safety-related applications (SIL 2)

When using the MACX MCR-EX-SL-NAM-R(-SP) in safety-related applications, observe the instructions in Section 9, as the requirements differ for safety-related functions.

5 Installation



NOTE: Electrostatic discharge

The device contains components that can be damaged or destroyed by electrostatic discharge. When handling the device, observe the necessary safety precautions against electrostatic discharge (ESD) according to EN 61340-5-1 and EN 61340-5-2.

5.1 Basic circuit diagram

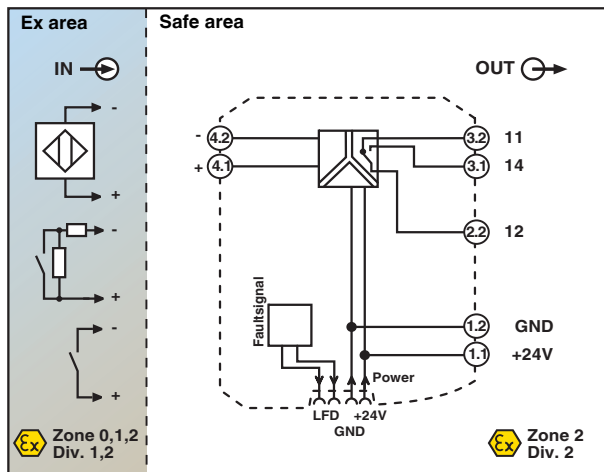

Figure 1 Basic circuit diagram with connection terminal blocks

5.2 Design

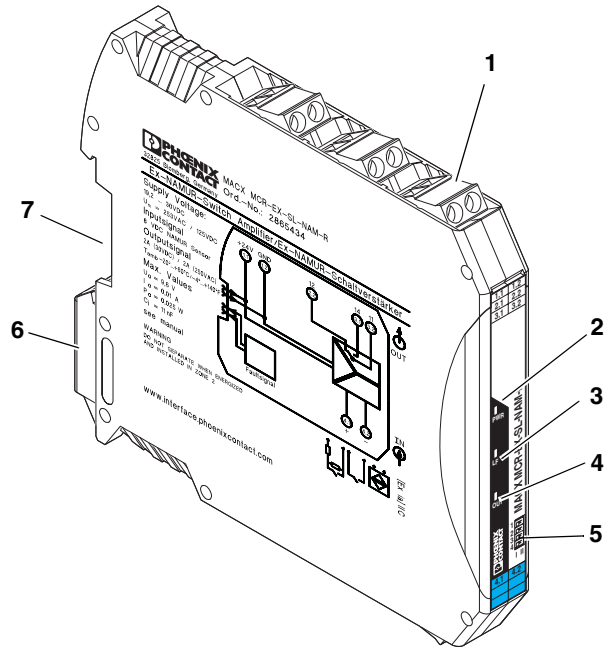

Figure 2 Design

- 1 COMBICON plug connectors
- 2 PWR LED (green), for indicating the power supply
- 3 LED LF1 (red), for indicating line faults on the sensor cable
- 4 LED OUT1 (yellow), for indicating switching state of the relay output
- 5 Switch DIP1 ... DIP4
- 6 Metal lock for fixing on the DIN rail
- 7 Connection option for DIN rail connector

5.3 Dimensions

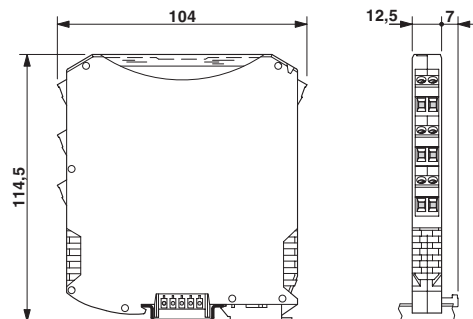

Figure 3 Dimensions (in mm)

5.4 Mounting



WARNING: Explosion hazard

If the module has been used in non-intrinsically safe circuits, it must not be used again in intrinsically safe circuits. Clearly label the module as being non-intrinsically safe.

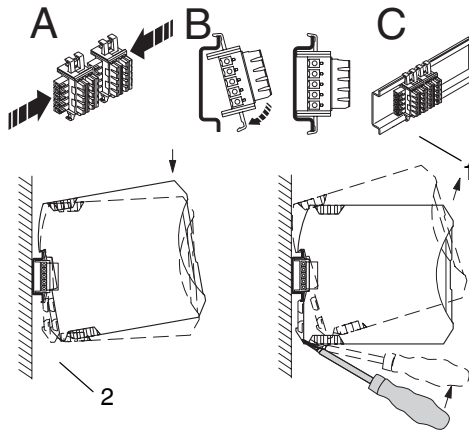

Figure 4 Assembly and removal

- Mount the module on a 35 mm DIN rail according to EN 60715.
- When using the DIN rail connector, first place it into the DIN rail (see A – C, Figure 4). It is used to bridge the voltage supply and for error messages.
Please also ensure you observe the direction of the module and DIN rail connector when snapping into position: Snap-on foot below (2) and connector left (1).
- Install the module in suitable housing to meet the requirements for the protection class.
- Before startup, check that the isolating amplifier is operating and wired correctly, especially with regard to the wiring and labeling of the intrinsically safe circuits.

5.5 Connecting the cables

- Pluggable screw terminal blocks (on MACX MCR-EX-SL-NAM-R); litz wires provided with ferrules.
- Pluggable spring-cage terminal blocks (on MACX MCR-EX-SL-NAM-R-SP); litz wires provided with ferrules.
- Lay intrinsically safe and non-intrinsically safe cables separately.
- Permissible cable cross-section: 0.2 mm² to 2.5 mm².

- Screw connection:

- Insert the wire into the corresponding connection terminal block.
- Use a screwdriver to tighten the screw in the opening above the connection terminal block.

- Spring-cage connection:

- Insert a screwdriver in the opening above the connection terminal block.
- Insert the wire into the corresponding connection terminal block.

5.6 Voltage supply



NOTE: Never connect the supply voltage directly to the DIN rail connector. It is not permitted to draw power from the DIN rail connector or from individual MACX-MCR-EX modules.

The modules can be powered via the connection terminal blocks 1.1 (+24 V) and 1.2 (GND) or via the DIN rail connector (ME 6.2 TBUS-... , order no. 2869728).

Depending on the number of modules to be powered, the voltage is either fed via the MACX MCR-EX-SL-NAM-R(-SP) or the power and error evaluation module MACX MCR-PTB(-SP) on the DIN rail connector.

Supply via the module

Where the total current consumption of the aligned modules does not exceed 400 mA, the power can be supplied directly at the connection terminal blocks of the module. A 400 mA fuse should be connected upstream.

The voltage supply is provided at the connection terminal blocks 1.1 (+24 V) and 1.2 (GND).

Infeed via the power and error evaluation module MACX MCR-PTB(-SP)

The supply voltage is fed in via the module MACX MCR-PTB(-SP) to the DIN rail connectors. The supply voltage can be provided as either simple or redundant.

The module MACX MCR-PTB(-SP) has integrated error evaluation. An auxiliary supply failure or fuse error is registered to a relay contact and displayed via a flashing LED. Collection line faults of all modules connected via the DIN rail connectors are also signaled.

6 Configuration

In the default state upon delivery, all DIP switches are set to the position "I".



- DIP1 = I Normal phase
- DIP1 = II Inverted phase
- DIP2 = I Line fault detection disabled*
- DIP2 = II Line fault detection enabled
- PWR = Supply voltage
- OUT = Switching state of the relay output
- LF = Line fault on the sensor cable

* (Not permitted for safety-related applications, SIL 2)

6.1 Line fault detection (switch DIP2)



WARNING: For safety-related applications, **only** the switch position "DIP2 = II" is **permitted**.

Line fault detection is enabled or disabled using switch DIP2. When line fault detection is enabled, the relay drops out in the event of a cable interrupt or short circuit to the sensor so that the output is set to the safe, non-conductive state. The red LED (LF) flashes.

Operating range for the

- Cable break alarm $50 \mu\text{A} > I > 350 \mu\text{A}$
- Short circuit alarm $100 \Omega > R > 360 \Omega$

If the module is connected to a power module MACX MCR-PTB(-SP) via a DIN rail connector, a group error message is also sent to the higher-level evaluation unit via floating relay output.



NOTE: For **switch contacts with open circuit** (Figure 5), line fault detection (DIP2 = I) must be disabled or the corresponding resistance circuit must be provided directly at the switch contact (Figure 6, e. g. UKK 5-2R/NAMUR (Order No. 2941662) with D-UKK 3/5 (Order No. 2770024)).

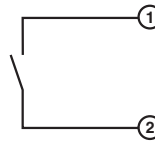

Figure 5 Switch contact with open circuit

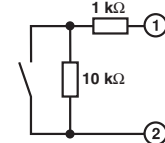

Figure 6 Switch contact with resistance circuit

(Not permitted for safety-related applications, SIL 2)

6.2 Phase reversal (switch DIP1)

The phase reversal function is enabled or disabled using switch DIP1.

Output relay	Normal phase (I)	Inverted phase (II)
Switched if	$I > 2.1 \text{ mA}$	$I < 1.2 \text{ mA}$
In normal position when	$I < 1.2 \text{ mA}$	$I > 2.1 \text{ mA}$

6.3 Truth table



WARNING: For safety-related applications, **only** the switch position "DIP2 = II" is **permitted**.



WARNING: Only switch contacts with resistance circuit are **permitted** at the input for safety-related applications (see Figure 6).

	Sensor in Input		Input circuit	DIP switches		Relay-contact output		LED OUT	LF LED
	Switch	NAMUR	State	1	2	N/O contact	N/C contact	Yellow	Red
	Open	Blocking	OK	I	I	Open	Closed		
	Closed	Conductive	OK	I	I	Closed	Open	X	
	Open	Blocking	OK	II	I	Closed	Open	X	
	Closed	Conductive	OK	II	I	Open	Closed		
		Blocking	OK	I	II	Open	Closed		
		Conductive	OK	I	II	Closed	Open	X	
		Any	Open circuit	I	II	Open	Closed		X
		Any	Short circuit	I	II	Open	Closed		X
		Blocking	OK	II	II	Closed	Open	X	
		Conductive	OK	II	II	Open	Closed		
		Any	Open circuit	II	II	Open	Closed		X
		Any	Short circuit	II	II	Open	Closed		X

DIP2 = I Line fault detection disabled
(not permitted for safety-related applications, SIL 2)

DIP2 = II Line fault detection enabled

DIP1 = I Normal phase

DIP1 = II Inverted phase

PWR LED = Supply voltage

LED OUT = Switching state of the relay output

LF LED = Line fault on the sensor cable

7 Comparison of safety data



WARNING: Explosion hazard

Compare the safety data before connecting a module located in the intrinsically safe area to the MACX MCR-EX-SL-NAM-R(-SP).

Safety data for

Field devices: U_i, I_i, P_i, L_i, C_i

NAMUR isolation amplifiers: U_o, I_o, P_o, L_o, C_o

For the values for U_o, I_o, P_o, L_o and C_o , please refer to "Safety data according to ATEX for intrinsically safe circuits" on page 4.

Requirements for intrinsic safety (simple circuits):

$$U_i \geq U_o$$

$$I_i \geq I_o$$

$$P_i \geq P_o$$

$$L_i + L_c \leq L_o$$

$$C_i + C_c \leq C_o$$

(L_c and C_c depend on the cables/lines used).

8 Switch on



NOTE: Around 5 seconds after switching on the main power, the module is ready for use. It depends on the operating conditions as to whether the module reaches its specified accuracy immediately or whether there is a warm-up period.

The greatest possible accuracy is achieved when the unit has been running for around 2 hours.

9 Safety-related applications (SIL 2)

9.1 Wiring

Input

Permitted for safety-related applications:

- NAMUR sensor (according to EN 60947-5-6)
- Switch contact with resistance circuit (1 k Ω serial and 10 k Ω parallel (tolerance $\pm 10\%$))
(Note: The resistance circuit regulates the behavior of a NAMUR sensor)



WARNING: Switch contacts without resistance circuit are **not permitted** for safety-related applications.

Output

The safety-related function at the output is dependent on the position of switch DIP1.

- I = Normal operation In the event of a 0-signal (NAMUR sensor high resistance, therefore lower current in the input circuit) the output (N/O contact) switches to the "non-conductive" state.
- II = Inverse function In the event of a 1-signal at the input, the output switches to the "non-conductive" state.

9.2 Diagnostic function of switch DIP2

For safety applications, line fault detection is enabled, i.e., the DIP2 switch is in the "II" position.



WARNING: The "DIP 2 = I" switch position is **not permitted** for safety-related applications.

When line fault detection is enabled, the red LED indicates any faults that occur. If a line fault is detected, the output is disabled ("non-conductive"). This behavior is not dependent on the position of the DIP1, DIP3 and DIP4 switches.

9.3 Safe state

The "safe state" means that the output is in a non-conductive state, i.e., the relay contact is open.

9.4 Response times

Following a state change at the input, the output enters the safe state in ≤ 40 ms.

9.5 Operating mode of the safety function

Operating mode as per EN 61508: "Low demand mode"

9.6 Failure behavior and required response

1. The safe state is entered in the event that a line fault is detected or the supply voltage fails (see Section 9.3).
2. The safe state is reached by removing the connection terminal blocks.

Startup and restart

Behavior	Description
Startup or restart of the device	The output enters the state without oscillation (according to the truth table on page 9). A reset is not required.
What happens when a line fault is detected and what must the user do?	The fault is indicated by the red LED and the output enters the "non-conductive" state regardless of the input signal and the operating mode (normal or inverse mode). The user must remove the line fault (short circuit or break in the sensor cable). The device output is not blocked when fault detection is triggered (no lock or reset). Undefined line states that occur during repairs can switch the output. The user must prevent this from happening by disconnecting the supply voltage or removing the connection terminal blocks. Other options that have the same result and do not present an additional hazard are permitted.
The line fault is removed.	The user must ensure that a defined state is entered using the truth table on page 9. The device is restarted in the same way as during initial startup. The device then behaves as described under "Startup or restart of the device".

9.7 Safety integrity requirements

Failure rates

- Type A device (according to EN 61508-2)
- Safety Integrity Level (SIL) 1 and 2

Non-inverted operation:

λ_{sd}	λ_{su}^*	λ_{dd}	λ_{du}	SFF [†]	DC _S [‡]	DC _D [‡]
6 FIT ^{**}	249 FIT	7 FIT	64 FIT	78%	2.4%	9%

* The SU (Safe Undetected) category includes failures that do not cause a spurious trip.

† SFF = Safe Failure Fraction

‡ DC = Diagnostic Coverage (safe or dangerous)

** FIT = Failure in Time (1 FIT = 1 failure/10⁹ h)

PFD_{AVG} values

T[PROOF] =	1 year	2 years	5 years
PFD _{AVG} [*] =	3.09E-04	6.17E-04	1.54E-03

* PFD = Probability of Failure on Demand

Inverted operation:

λ_{sd}	λ_{su}^*	λ_{dd}	λ_{du}	SFF [†]	DC _S [‡]	DC _D [‡]
1 FIT ^{**}	248 FIT	6 FIT	62 FIT	78%	0.4%	8%

* The SU (Safe Undetected) category includes failures that do not cause a spurious trip.

† SFF = Safe Failure Fraction

‡ DC = Diagnostic Coverage

** FIT = Failure in Time (1 FIT = 1 failure/10⁹ h)

PFD_{AVG} values

T[PROOF] =	1 year	2 years	5 years
PFD _{AVG} [*] =	3.01E-04	6.02E-04	1.50E-03

* PFD = Probability of Failure on Demand

The boxes marked in white mean that the calculated PFD_{AVG} values are within the allowed range for SIL 2 according to table 2 of EN 61508-1, but do not fulfill the requirement to not claim more than 10% of this range, i.e., to be better than or equal to 1.00E-03.

The boxes marked in gray mean that the calculated PFD_{AVG} values are within the allowed range for SIL 2 according to table 2 of EN 61508-1, and do fulfill the requirement to not claim more than 10% of this range, i.e., to be better than or equal to 1.00E-03.

Failure limit

The operating mode is based on low demand mode. The percentage of the device at PFH/PFD for the overall safety loop is less than 10%.

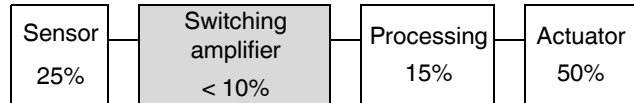

Figure 7 Safety loop

Conditions

- The failure rates of the components used remain constant throughout the period of use.
- Propagation of errors by the device in the system is not taken into consideration.
- The repair time (= replacement) should take eight hours.
- The failure rates of the external power supply are not taken into consideration.
- The average temperature at which the device is to be used is +40°C. This is based on standard industrial conditions.

The failure rates given refer to an ambient temperature of +40°C. For an ambient temperature of +60°C, you will need to multiply the failure rates by a factor of 2.5. The factor of 2.5 is based on empirical values gathered.

9.8 Proof test

1. Carry out the appropriate steps to prevent incorrect use.
2. An appropriate signal is applied at the input of the MACX MCR-EX-SL-NAM-R in order to obtain the non-conductive state at the output. Check whether the output is non-conductive.
3. Restore the safety circuit to full functionality.
4. Return to normal operation.

With this test, around 99% of possible "du" ("dangerous undetected") errors are uncovered in the repeater power supply.